

## Digital Dual-Phase Synchronous Buck Controller

### FEATURES

- Digital Dual-Phase Synchronous Buck PWM Controller With 175ps PWM Resolution
- Digital Control With Programmable Compensation
- Dual-Phase With Current Balancing Capability
- VOUT from 0.4V to 4.0V
- Programmable Switching Frequency, Capable of up to 1MHz
- Programmable Soft Start and Soft Stop
- Supports Pre-Biased Start-Up
- Supports Voltage Tracking
- Supports Remote Differential Voltage Sensing
- Supports Fan Speed Adjustment and Monitor
- Single 3.3V Bias Supply
- Internal and External Thermal Sensor
- Fault Logging
- Graphical User Interface Configuration
- PMBus Support
  - Query Voltage, Current, Faults, etc.
  - Voltage Setting and Calibration
  - Protection Threshold Adjustment
- 32-Pin QFN Package

### APPLICATIONS

- DC Power Distributed Systems
- Industrial / ATE
- Networking Equipment
- Servers
- Storage Systems
- Telecommunications Equipment

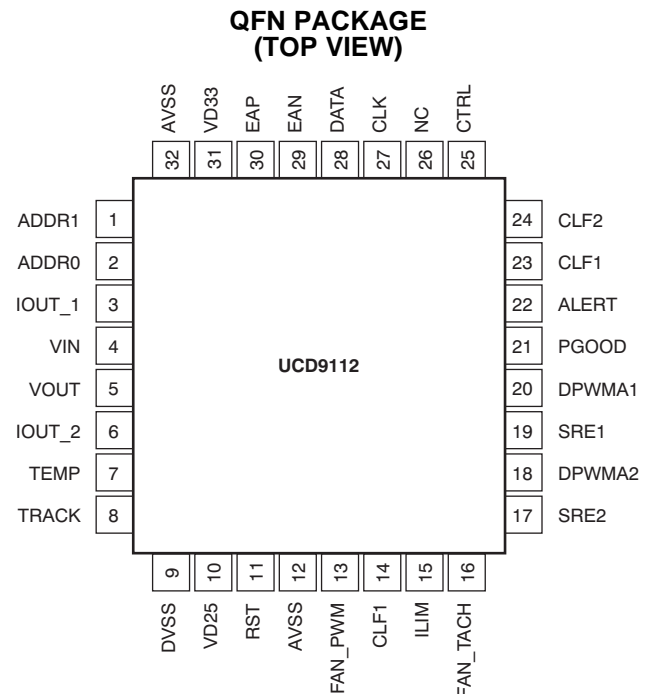

### DESCRIPTION/ORDERING INFORMATION

The UCD9112 is a dual-phase synchronous buck digital PWM controller designed for point of load power applications. This device integrates dedicated circuitry for DC/DC loop management with a microcontroller core, flash memory and a PMBus™ interface to support configurability, monitoring and management of a point of load. The UCD9112 is capable of operating at switching frequencies of up to 1MHz.

The UCD9112 evaluation module comes with the Fusion Digital Power Designer graphical user interface (GUI). This GUI allows the designer to configure the operating parameters and loop response of the power supply controller. This configuration can then be stored to the devices on chip non-volatile memory. This will enable a synchronous buck hardware design to be dynamically calibrated and reconfigured to optimize a single hardware design for a variety of applications.

The UCD7230 synchronous buck driver has been designed to work with the UCD9112 controller to provide a highly integrated digital power solution. In addition to 4A output drive capability, the driver integrates current limit, short circuit protection as well as under-voltage lockout protection. The UCD7230 also has a 3.3V, 10mA linear regulator that provides the supply current for the controller.



Please be aware that an important notice concerning availability, standard warranty, and use in critical applications of Texas Instruments semiconductor products and disclaimers thereto appears at the end of this data sheet.

All trademarks are the property of their respective owners.



This integrated circuit can be damaged by ESD. Texas Instruments recommends that all integrated circuits be handled with appropriate precautions. Failure to observe proper handling and installation procedures can cause damage.

ESD damage can range from subtle performance degradation to complete device failure. Precision integrated circuits may be more susceptible to damage because very small parametric changes could cause the device not to meet its published specifications.

### ORDERING INFORMATION

PACKAGE <sup>(1)</sup>	TAPE AND REEL QUANTITY	PART NUMBER
QFN	3000	UCD9112RHBR
QFN	250	UCD9112RHBT

- (1) For the most current package and ordering information, see the Package Option Addendum located at the end of this datasheet or see the TI website at [www.ti.com](http://www.ti.com).

### ABSOLUTE MAXIMUM RATINGS<sup>(1)</sup>

over operating free-air temperature range (unless otherwise noted)

PARAMETER	UCD9112	UNIT
VD33 relative to AVSS	–0.3 to 3.6	V
IO pin relative to DVSS	–0.3 to 3.6	V
Maximum junction temperature, $T_J$	–40 to 125	°C
Storage temperature, $T_{stg}$	–65 to 150	°C
Lead temperature (soldering for 10 seconds)	300	°C

- (1) Stresses beyond those listed under absolute maximum ratings may cause permanent damage to the device. These are stress ratings only, and functional operation of the device at these or any other conditions beyond those indicated under recommended operating conditions is not implied. Exposure to absolute-maximum-rated conditions for extended periods may affect device reliability.

### RECOMMENDED OPERATING CONDITIONS

over operating free-air temperature range (unless otherwise noted)

	MIN	TYP	MAX	UNIT
VD33 relative to AVSS	3.14	3.3	3.46	V
VEAP relative to VEAN	0		2.45	V
Operating free-air temperature	–40		125	°C

### ELECTROSTATIC DISCHARGE (ESD) PROTECTION

PARAMETER	MIN	TYP	MAX	UNIT
HBM (Human Body Model)	2000			V
CDM (Charged Device Model)	500			V

**ELECTRICAL CHARACTERISTICS**

 VD33 = 3.3V, T<sub>A</sub> = -40°C to 125°C (unless otherwise noted).

PARAMETER		CONDITIONS	MIN	TYP	MAX	UNIT
<b>VDD Input Supply</b>						
VD33 supply voltage			3.14	3.3	3.46	V
Supply current	I <sub>CC</sub>	Normal operation	4	8	10	mA
VD33 rise time			1			ms
<b>VD25</b>						
Voltage reference		1μF ceramic connected, without source current	2.426	2.45	2.475	V
<b>Power on Reset (POR)</b>						
Power-on Reset 1		VD33 rising edge		3.0		V
Power-on Reset 2		VD33 falling edge		1.8		V
<b>EAP and EAN</b>						
Input differential range		EAP - EAN	-0.2		2.475	V
EAP bias current		EAP connected to AVSS			-15	μA
EAP bias current		V <sub>EAP</sub> = 2.475V			30	μA
EAN bias current		EAN connected to AVSS		-10		μA
Error ADC accuracy				±0.5		%
Error ADC resolution				±2.5		mV
<b>Internal Temperature Sensor</b>						
Resolution				1		°C
Accuracy		After calibration by adjusting offset at 25°C		±3		°C
<b>DPWM Output</b>						
Duty cycle			0		99	%
Rise time	t <sub>r</sub>	47pF cap load		15		ns
Fall time	t <sub>f</sub>	47pF cap load		15		ns
PWM frequency	F <sub>sw</sub>		250	500	1000	kHz
Frequency set point accuracy		T <sub>A</sub> = 25°C			±5	%
Frequency change		-40 to 125°C		±10		%
<b>ILIM Reference Generator</b>						
PWM frequency	F <sub>ILIM</sub>			25		kHz
Duty cycle range			0		100	%
<b>Power Good (PGOOD)</b>						
Low-level output voltage	V <sub>OL</sub>	I <sub>PGOOD</sub> = 5 mA			0.4	V
High-level output voltage	V <sub>OH</sub>	I <sub>PGOOD</sub> = -5 mA	2.8			V
<b>PMBus Alert</b>						
Low-level output voltage	V <sub>OL</sub>	I <sub>ALERT</sub> = 5 mA			0.4	V
High-level output voltage	V <sub>OH</sub>	I <sub>ALERT</sub> = -5 mA	2.8			V
<b>I/O Characteristics</b>						
High input voltage	V <sub>IH</sub>	VD33 = 3.3V	2		3.45	V
Low input voltage	V <sub>IL</sub>	VD33 = 3.3V			0.8	V
Output voltage high	V <sub>OH</sub>	VD33 = 3.3V, I <sub>OH</sub> = -5mA	2.8			V
Output voltage low	V <sub>OL</sub>	VD33 = 3.3V, I <sub>OL</sub> = 5mA			0.4	V

**ELECTRICAL CHARACTERISTICS (continued)**VD33 = 3.3V, T<sub>A</sub> = –40°C to 125°C (unless otherwise noted).

PARAMETER		CONDITIONS	MIN	TYP	MAX	UNIT
<b>PMBus/SMBus</b>						
FSMB PMBus/SMBus operating frequency		Slave mode, SMBC 50% duty cycle		100		kHz
Bus free time between start and stop	t <sub>(BUF)</sub>		4.7			μs
Hold time after (repeated) start	t <sub>(HD:STA)</sub>		4.0			μs
Repeated start setup time	t <sub>(SU:STA)</sub>		4.7			μs
Stop setup time	t <sub>(SU:STO)</sub>		4.0			μs
Data hold time	t <sub>(HD:DAT)</sub>	Receive Mode	0			ns
		Transmit Mode	300			ns
Data setup time	t <sub>(SU:DAT)</sub>		250			ns
Error signal/detect <sup>(1)</sup>	t <sub>(TIMEOUT)</sub>		25		35	ms
Clock low period	t <sub>(LOW)</sub>		4.7			μs
Clock high period <sup>(2)</sup>	t <sub>(HIGH)</sub>		4.0		50	μs
Cumulative clock low slave extend time <sup>(3)</sup>	t <sub>(LOW:SEXT)</sub>				25	ms
Cumulative clock low master extend time <sup>(4)</sup>	t <sub>(LOW:MEXT)</sub>				10	ms
Clock/data fall time <sup>(5)</sup>	t <sub>f</sub>				300	ns
Clock/data rise time <sup>(6)</sup>	t <sub>r</sub>				1000	ns

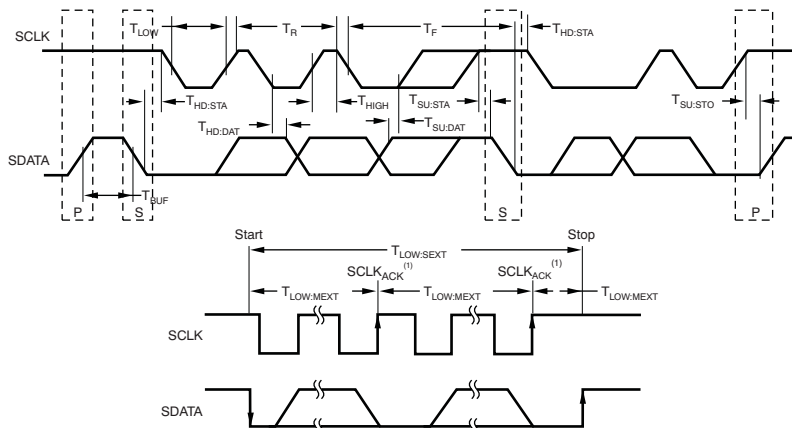
(1) The UCD9112 times out when any clock low exceeds t<sub>(TIMEOUT)</sub>.(2) t<sub>(HIGH), Max</sub>, is the minimum bus idle time. SMBC = SMBD = 1 for t > 50 ms causes reset of any transaction involving UCD9112 that is in progress. This specification is valid when the NC\_SMB control bit remains in the default cleared state (CLK[0]=0).(3) t<sub>(LOW:SEXT)</sub> is the cumulative time a slave device is allowed to extend the clock cycles in one message from initial start to the stop.(4) t<sub>(LOW:MEXT)</sub> is the cumulative time a master device is allowed to extend the clock cycles in one message from initial start to the stop.(5) Fall time t<sub>f</sub> = 0.9VDD to (V<sub>ILMAX</sub> – 0.15)(6) Rise time t<sub>r</sub> = (V<sub>ILMAX</sub> – 0.15) to (V<sub>IHMIN</sub> + 0.15)NOTE: (1) SCLK<sub>ACK</sub><sup>(1)</sup> is the acknowledge-related clock pulse generated by the master.**Figure 1. PMBus/SMBus Timing Diagram**

## DEVICE INFORMATION

### UCD9112 Dual Phase Sync Buck Controller

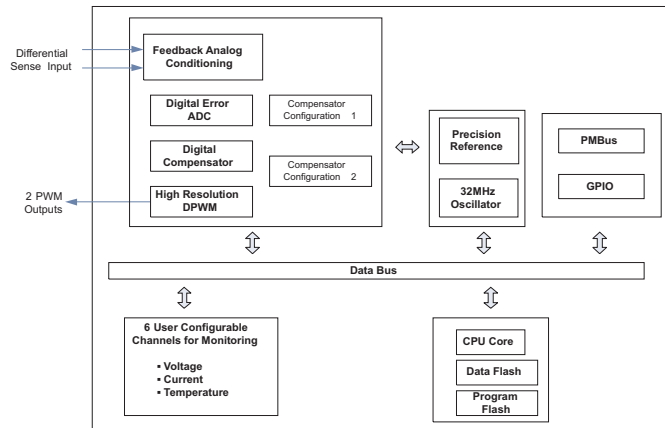

Figure 2. UCD9112 Block Diagram

Table 1. TERMINAL FUNCTIONS

TERMINAL PIN				DESCRIPTION
NAME	NO.	I/O	A/D	
ADDR1	1	I	A	ADDR1 and ADDR0 signals are analog voltage inputs that are sampled when the UCD9112 is released from reset. The voltage levels set the PMBus address that is used. See the section, PMBus Address Configuration.
ADDR0	2	I	A	
IOUT_1	3	I	A	Phase 1 inductor current, the value is amplified in the UCD7230.
VIN	4	I	A	Input DC voltage sensing through resistors.
VOUT	5	I	A	Output DC voltage sensing through resistors.
IOUT_2	6	I	A	Phase 2 inductor current sensing, the value is amplified in the UCD7230.
TEMP	7	I	A	Temperature remote sensing input.
TRACK	8	I	A	Voltage tracking input.
DVSS	9	-	DG	Digital ground of IC. This ground should be separate from power ground.
VD25	10	O	P	Internal 2.5V bypass pin for the UCD9112. A 1 $\mu$ F ceramic cap must be connected from VD25 to DVSS.
RST	11	I	-	Pulling high resets the chip. Need a pull-down resistor and a 0.1 $\mu$ F decoupling capacitor.
AVSS	12	-	AG	Connected to analog ground.
FAN_PWM	13	O	D	Output PWM pulse to drive a fan.
CLF1	14	I	D	Phase 1 over current limit flag from the UCD7230.
ILIM	15	O	D	A PWM output that is used to generate an analog input to the UCD7230 current limit. The ILIM requires an RC filter consisting of 3.83K and 0.47 $\mu$ F
FAN_TACH	16	I	D	Input pulses from fan tach.
SRE2	17	O	D	Phase 2 Sync FET enable.
DPWMA2	18	O	D	Phase 2 DPWM output to the driver UCD7230.
SRE1	19	O	D	Phase 1 Sync FET enable.
DPWMA1	20	O	D	Phase 1 DPWM output to the driver UCD7230.
PGOOD	21	O	D	Power good signal indicating power conversion status.
ALERT	22	O	D	Alert signal indicating PMBus status.
CLF1	23	I	D	Phase 1 over current limit flag from the UCD7230.
CLF2	24	I	D	Phase 2 over current flag from the UCD7230.
CTRL	25	I	D	ON/OFF command to turn on/off power supply output.

**DEVICE INFORMATION (continued)****Table 1. TERMINAL FUNCTIONS (continued)**

TERMINAL PIN				DESCRIPTION
NAME	NO.	I/O	A/D	
NC	26	-	D	Open connection.
CLK	27	I	D	PMBus/SMBus clock input.
DATA	28	I/O	D	PMBus/SMBus data (bi-directional).
EAN	29	I	A	Output voltage remote sensing to error amplifier negative input.
EAP	30	I	A	Output voltage remote sensing to error amplifier positive input.
VD33	31	I	P	3.3V VDD bias supply.
AVSS	32	-	AG	Analog ground.
PAD GND	33	-	Pad	Thermal pad connected to analog ground.

**APPLICATION INFORMATION**

**Example Dual-Phase Implementation With the UCD7230 Driver**

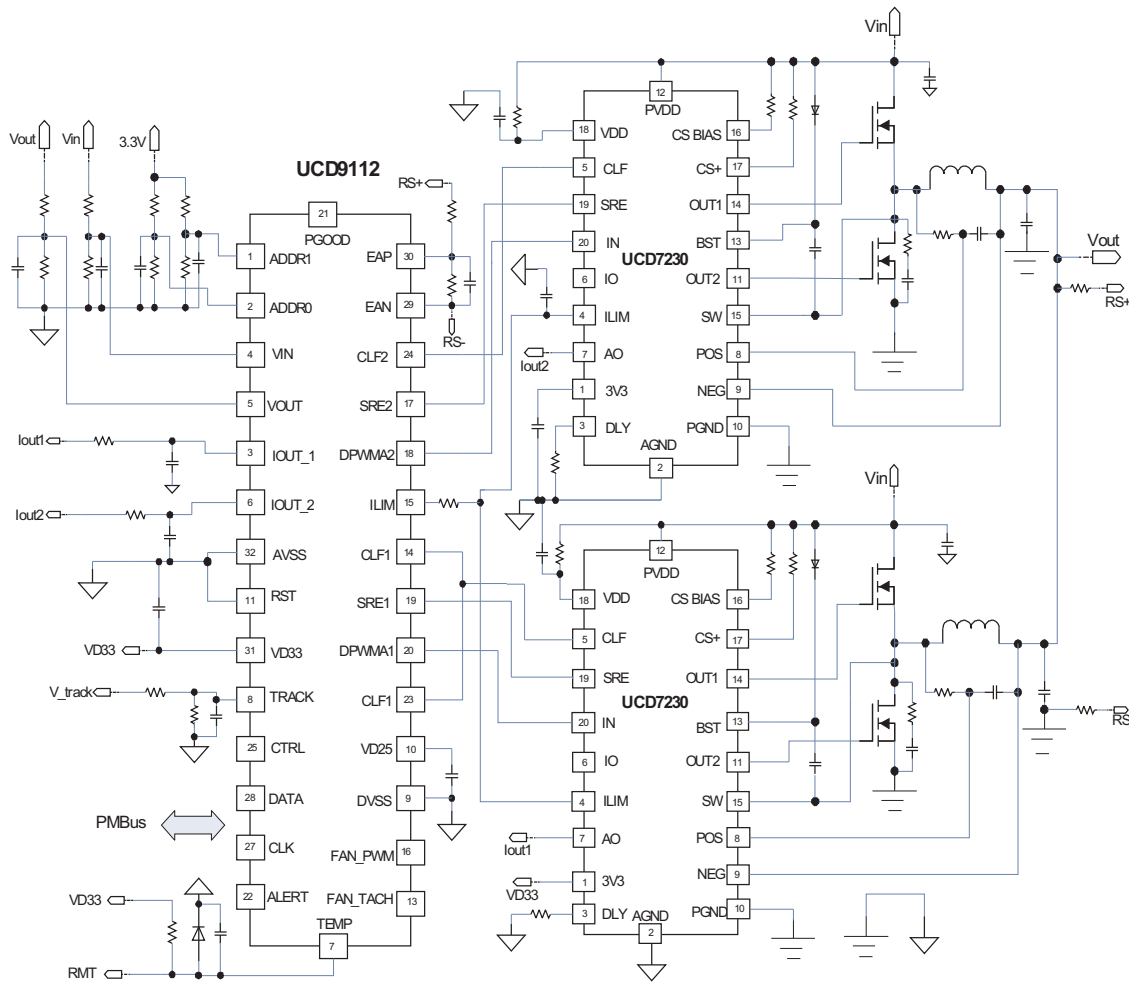

**Figure 3. UCD9112 in a Dual Phase Configuration**

## FUNCTIONAL OVERVIEW

### Reset

#### Power-on Reset

The UCD9112 has an integrated power-on reset (POR) circuit which monitors the supply voltage. At power-up, the POR detects the VD33 rise. When VD33 is greater than a predetermined reference point, the device initiates a startup delay sequence. At the end of the delay sequence, the system reset signal is de-asserted and the device begins normal operation (See Electrical Characteristics).

#### External Reset

The device can be forced into the reset state by an external circuit connected to the RST pin. A logic high voltage on this pin generates a reset signal. To avoid an erroneous trigger caused by the noise, a pull down resistor and a decoupling capacitor is necessary.

### Analog Monitoring

The UCD9112 monitors eight analog signals to determine supply operation. [Table 2](#) shows the analog input pin assignments.

**Table 2. Analog Input Assignment**

PIN NO.	PIN NAME	FUNCTION/DESCRIPTION
1	ADDR1	Address 1 voltage conversion (for PMBus address configuration)
2	ADDR0	Address 0 voltage conversion (for PMBus address configuration)
3	IOUT_1	Phase 1 current conversion
4	VIN	POL input voltage conversion
5	VOUT	POL output voltage conversion
6	IOUT_2	Phase 2 current conversion
7	TEMP	Remote temperature sensing conversion
8	TRACK	Voltage tracking reference conversion

The UCD9112 takes the proper actions based on the information acquired from these analog inputs, for example, turning off the DC output or sending alarm signal to the host system if the output is under voltage. The internal device temperature is monitored by internal ADC. The status of power supply can be queried any time by the PMBus master.

### Resolution

The UCD9112 uses an internal 2.45V as ADC reference, with a resolution of 2.39mV. The internal reference has  $\pm 1\%$  accuracy over temperature. In some applications, an external voltage divider should be used to insure analog inputs are constrained to a range of zero to 2.45V.

### Input Impedance

The input impedance is typically a  $250\Omega$  ( $R_{in}$ ) series input and a 30pF ( $C_{S/H}$ ) capacitor to ground. It is recommended to have a  $0.1\mu\text{F}$  ( $C_{in}$ ) input capacitor at each analog input pin. [Figure 4](#) is the equivalent ADC sampling circuit.



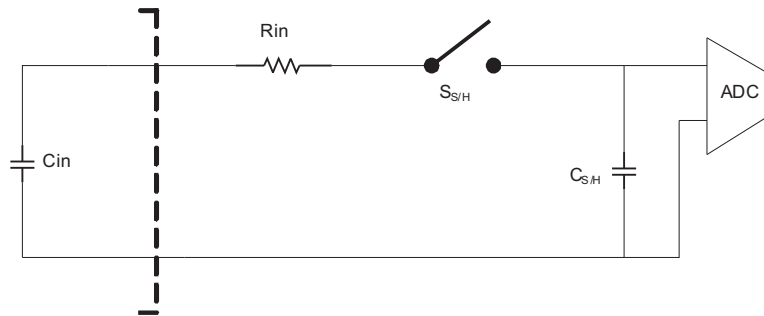

Figure 4. Equivalent ADC sampling circuit

### PMBus Address Configuration

In order to support multiple POL converters in a system, each converter needs to have the ability to be configured with unique PMBus address. To configure the UCD9112 with a specific PMBus address, a proper voltage needs to be applied to the pins ADDR1 and ADDR0. Figure 5 shows what PMBus addresses are indicated by the applied voltage.

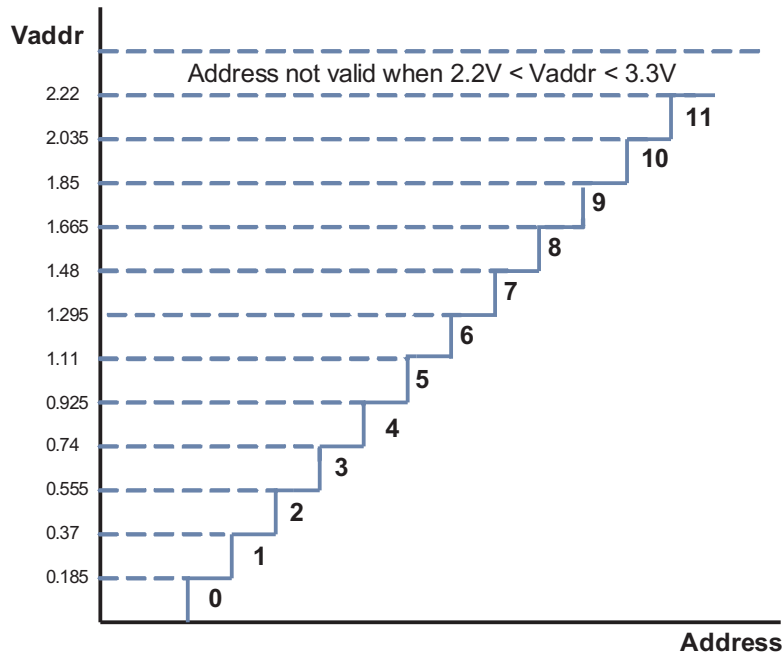

Figure 5. V<sub>ADDR</sub> to PMBus Address Translation

Note that the nominal value for each voltage step (and each PMBus address) is in the center of each band.

The address can be represented by the formula:

$$PMBus\_Address = ADDR1 * 12 + ADDR0$$

Table 3 lists the examples of the PMBus address for the given voltage level on the ADDR0 and ADDR1.

**Table 3. PMBus Address Configurations**

ADDR1	ADDR0	PMBus Address	ADDR1	ADDR0	PMBus Address
<0.185	<0.185	0x00	0.185-0.37	<0.185	0x0C
	0.185-0.37	0x01		0.185-0.37	0x0D
	0.37-0.555	0x02		0.37-0.555	0x0E
	0.555-0.74	0x03		0.555-0.74	0x0F
	0.74-0.925	0x04		0.74-0.925	0x10
	0.925-1.11	0x05		0.925-1.11	0x11
	1.11-1.295	0x06		1.11-1.295	0x12
	1.295-1.48	0x07		1.295-1.48	0x13
	1.48-1.665	0x08		1.48-1.665	0x14
	1.665-1.85	0x09		1.665-1.85	0x15
	1.85-2.035	0x0A		1.85-2.035	0x16
	2.035-2.22	0x0B		2.035-2.22	0x17

The other addresses can be figured out by using the above formula. If the voltage applied on the address pins is over 2.22V, it is decoded as 127; or if both address pins are connected to ground, the PMBus address is decoded as 127.

### PID Compensator

The UCD9112 has a digital voltage mode controller, or compensator, that has been implemented in digital PID format. This PID compensator allows output voltage regulation at the set point reference level with zero steady state error and good dynamic performance. The integrator in the PID compensator results in the high DC gain in the control loop and thereby maintains the zero steady state error. In the complex s-plane, the PID compensator transfer function shows a single pole at  $s=0$ , two adjustable compensator zeros and an adjustable gain factor. For good dynamic performance of the power supply output, the power supply designer needs to properly select these compensator zeros and the gain factor in order to achieve acceptable loop bandwidth with optimum phase and gain margin. The graphical user interface (GUI) provided with the UCD9112 allows the designer an easy way to select these PID parameters and verify the control loop design by reviewing the loop gain Bode plots. Once a control loop design looks acceptable, the GUI calculates the coefficients of the digital PID compensator and generates the compensator coefficients. These coefficients can then be stored in the UCD9112's non-volatile and operating memory.

The synchronous buck topology is commonly used for non-isolated DC/DC converters. The choice of PID compensator gain and zeros are determined by the power stage parameters such as input voltage, PWM frequency, output filter inductor, capacitor, and the parasitic components. In the traditional analog power supply design, an operational error amplifier and external compensation components are used to implement the compensator. For the UCD9112, this is achieved by using the on-chip error ADC (EADC) and the look-up table based PID compensator. In this case, the output voltage is first scaled and filtered appropriately before applying it into the UCD9112 EADC. The EADC output is used by the UCD9112 on-chip PID compensator in order to generate a control signal for use in the DPWM module. The DPWM module finally generates the required PWM outputs for the buck converter switches based on the PID compensator control output.

## Output Voltage Remote Sensing

Figure 6 shows the voltage sensing circuitry for the UCD9112. It is part of feedback loop. Two dedicated pins, EAP and EAN, are employed to sense the output differential voltage. The differential voltage sensing can effectively reduce the common-mode noise. The maximum voltage applied on the VEAP and VEAN pins should be less than 2.45V. If the output voltage is higher than 2.45V, a voltage divider should be used to decrease the voltage level applied to the pin below 2.45V to avoid error ADC saturation.

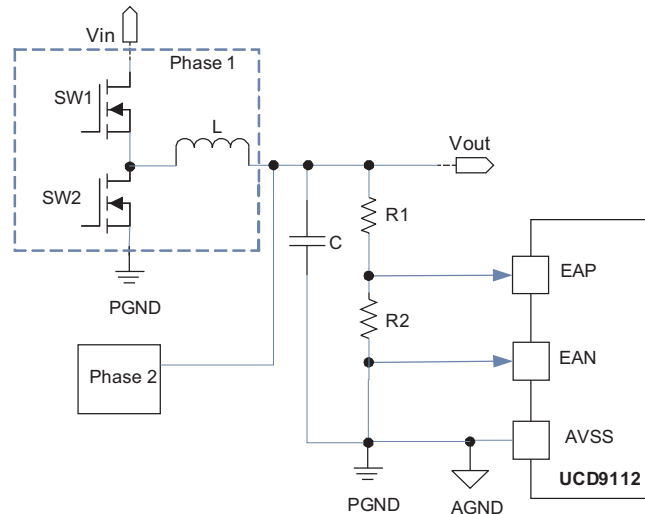

Figure 6. Output Voltage Sensing Circuitry

## OTHER FUNCTIONS

### Output Enable

The UCD9112 can be configured to begin power conversion in the following ways:

1. As soon as it detects sufficient input voltage;
2. As soon as it detects sufficient input voltage and the Control line is toggled to active state by a HOST/Sequencer;
3. As soon as it detects sufficient input voltage and the relevant PMBus command is received.

This feature is configurable and is supported by a combination of the PMBus commands and the state of the Control signal. For more details, refer to the “PMBus Support for the UCD911X” application note.

### Input Voltage Calibration

The UCD9112 periodically monitors the input voltage. The PMBus master can read the input voltage value by a PMBus command. In most applications, the input voltage is connected to the VIN pin using an external voltage divider. The voltage level is lowered to match the device’s internal ADC input voltage range. To compensate for the tolerances of this voltage divider, the input voltage monitoring path might need to be calibrated. This input voltage calibration is performed by adjusting the input voltage monitoring scale (VIN\_SCALE\_MONITOR) value using the relevant PMBus command. For more details, refer to the “PMBus Support for the UCD911X” application note.

### Output Voltage Calibration

Similar to the input voltage connection, the output voltage may be connected to the UCD9112 through an external voltage divider. The output voltage level may need to be scaled to match the device’s ADCs (Error ADC and 10bit-ADC) input voltage ranges using two independent voltage dividers.

### OTHER FUNCTIONS (continued)

1. One of the voltage dividers may be used to connect the output voltage to the EAP pin. This path is used to close the compensation loop and provides the high-speed Error-ADC with the required feedback signal. To compensate for the tolerances of this voltage divider, the calibration of loop scale calibration is required. Loop scale calibration is performed by adjusting the loop scale value using the VOUT\_SCALE\_LOOP PMBus command.
2. The second voltage divider may be used to connect the output voltage to the VOUT pin. This path is used to monitor the output voltage and provides the 10bit-ADC with the required signal for fault detection and output voltage reporting purposes. To compensate for the tolerances of this voltage divider, the output voltage monitor scale calibration is required. The output voltage monitoring signal calibration is performed by adjusting the monitoring scale value using the VOUT\_SCALE\_MONITOR PMBus command.

In addition, the output voltage may be trimmed using the VOUT\_TRIM command. For more details, refer to the “PMBus Support for the UCD911X” application note.

### Output Current Calibration

The UCD9112 can measure the current from each phase via the UCD7230 gate driver. The measurement of the inductor current for each phase is made by measuring a voltage equivalent to the voltage across the DCR of each output inductor shown in [Figure 7](#).

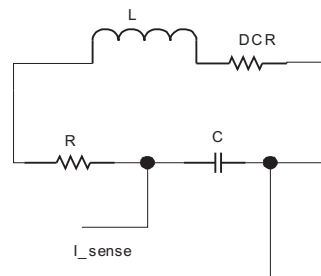

**Figure 7. Inductor Current Sensing Circuit**

The voltage across the inductor’s DCR is equal to the voltage across capacitor C if the time constant of  $L/DCR = RC$  is met. Slight mismatch in the time constants only affects measured accuracy during transients. The DC value of the voltage on the C will always track the DC value of the voltage on the DCR. This voltage is measured and amplified by the UCD7230 gate driver and reported to the UCD9112 via the IOUT\_1 or IOUT\_2 analog inputs, depending on the phase. The UCD9112 calculates the total current by the addition of two phase currents. Each phase current is calculated by the formula:

$$IOUT\_X = Offset\_X = Gain\_X * I\_sense\_X$$

Where: X represents the phase number.

These calibration parameters can be different on each phase due to tolerances of the selected components. The current measurements are calibrated by adjusting the offset and gain of the phase current inputs through the PMBus. The gain term includes the gain of the UCD7230 differential amplifier and the value of the inductor DCR. The DCR value is assumed to have a temperature coefficient of copper. The DCR value is compensated by the temperature value reported by the external temperature sensor.  $I\_sense$  is the voltage across the DCR. A current amplifier built in the UCD7230 is used to amplify this voltage for the UCD9112. For more details on configuration of the gain and offset for current measurement, refer to the “PMBus Support for the UCD911X” application note.

### Phase Current Balancing

The UCD9112 is a dual-phase synchronous buck PWM controller. Each phase is driven by a UCD7230 gate driver. Each UCD7230 gate driver includes a differential amplifier for inductor current sensing. This value is also offset so that bidirectional current can be measured. The analog value is output on the A0 pin of the UCD7230.

The UCD9112 uses two pins, IOUT\_1 and IOUT\_2, to sense the phase currents from each UCD7230. Since the components in each phase are different, each of the phase currents can be different when provided with the

## OTHER FUNCTIONS (continued)

same duty-cycle. The UCD9112 performs phase current balancing during regulation when both phases are enabled. It is implemented by adjusting the individual phase duty-cycles so that each phase can have matching inductor current. The current difference between two phases is within 5% of load current when output current is over 50% of full load. There is no current balancing implemented in the UCD9112 if the load current is less than 2A.

### Output Sequencing

The UCD9112 supports output voltage sequencing. Sequencing can be implemented by configuring each individual power supply with a different turn-on-delay (TON\_DELAY), rise-time (TON\_RISE), turn-off-delay (TOFF\_DELAY), and fall-time (TOFF\_FALL) values. During sequencing, each power supply unit supplies power to a separate voltage rail and all power supply units are commanded to turn their output on (or off) simultaneously by a single via the PMBus Control line or group command. All the above parameters are configurable using PMBus commands. This allows a user to implement different sequencing scenarios such as Sequential, Ratiometric, Simultaneous, etc. For more details, refer to the “PMBus Support for the UCD911X” application note.

### Soft-start and Soft-stop

The UCD9112 supports soft-start and soft-stop functionality. The turn-on-delay (TON\_DELAY), rise-time (TON\_RISE), turn-off-delay (TOFF\_DELAY), and fall-time (TOFF\_FALL) values are configurable using PMBus commands. These parameters are specified in milli-seconds, and have a range of zero to 255 milliseconds. The UCD9112 doesn't support soft-stop at light load. Output voltage is turned off directly and there is no soft-stop if load current is less than 2A. The [Figure 8](#) illustrates the four time intervals in the soft-start/stop sequence.

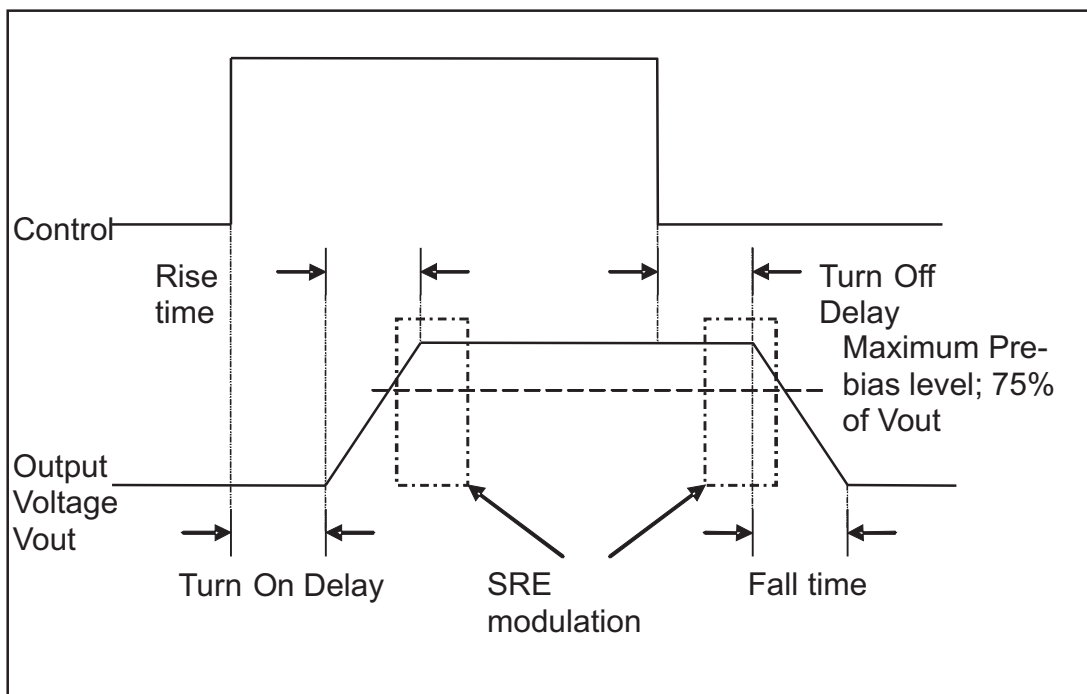

**Figure 8. Soft start/stop timings and SRE modulation**

## OTHER FUNCTIONS (continued)

### SRE Modulation

The UCD9112 supports output voltage ramp up and ramp down, even when a voltage is already present at the output terminals. This voltage which is persistent even when the device's output is off is commonly referred to as pre-bias voltage. Under typical circumstances, the power supply start-up (or shut-down) should not affect the pre-bias voltage and the output stage switches should not draw (sink) current. In order to avoid current sink via the lower FET (SYNC-FET), UCD7230's SRE pin is turned off by the UCD9112 controller.

Since turning SYNC-FET on and off during the operation has adverse effect on output voltage (causes transients), the UCD9112 turns SYNC-FET on and off gradually by varying (increasing or decreasing) the pulse width of the signal connected to the UCD7230's SRE pin.

In start-up (soft-start) scenario, the SRE is kept in off position as long as the output voltage is lower than the maximum possible pre-bias voltage level (75% of the configured output voltage set point). When the maximum pre-bias voltage is crossed, the UCD9112 gradually turns on the SRE signal. This is done by gradually increasing the pulse width of the PWM signal generated specifically for this purpose.

In shut-down (soft-stop) scenario, the SRE is switched to off position before the output voltage gets lower than the maximum possible pre-bias voltage level. Before the maximum pre-bias voltage is crossed, the UCD9112 gradually turns off the SRE signal. This is done by gradually decreasing the pulse width of the PWM signal generated specifically for this purpose.

The SRE modulation does not happen during the lower 75% of ramp-up and the lower 75% of ramp-down time intervals. Therefore, for proper start-up (or shut-down) into pre-bias, the pre-bias voltage can not be more than 75% of the configured output voltage set point. Figure 5-2 illustrates SRE modulation time intervals in the soft-start/stop sequence.

### Start-up with Pre-bias

The UCD9112 supports soft-start with existing pre-bias output voltage. When the output is enabled, the UCD9112 checks the output for the presence of pre-bias voltage. The UCD9112 reacts to pre-bias voltage level as follows:

If ( $\text{Prebias} < \text{Prebias\_min}$  (300 mV default)), the start-up is performed assuming no pre-bias. The device proceeds through standard soft-delay/soft-start sequence.

If ( $\text{Prebias} > \text{Prebias\_max}$  (3.65 V default)), the device does not attempt start-up and reports the specific fault in the status registers.

If ( $\text{Prebias} > \text{output voltage set point}$ ), the device ramps down the output voltage to the output voltage set point.

If ( $\text{Prebias} < \text{output voltage set point}$ ), the device ramps up the output voltage to the output voltage set point.

### Voltage Tracking

The UCD9112 supports output voltage tracking by following the voltage on its TRACK pin. This feature can be enabled or disabled by the TRACKING\_ENABLE. By default, the feature is disabled.

The voltage on the TRACK pin is referred as a parent's voltage, and is usually driven by another power supply referred as the parent or master device. When the tracking power supply (the UCD9112 in this case) is commanded to startup, the output voltage starts to track the parent's voltage.

The voltage tracking starts only when the voltage on the TRACK pin is greater than 300mV and ends when the UCD9112's output voltage reaches its configured output voltage level that is specified by VOUT\_COMMAND.

During tracking, the UCD9112's output follows the parent's output with an accuracy of  $\pm 100\text{mV}$ . The UCD9112 is capable of following the parent's voltage slew rates of up to  $100\text{mV/ms}$ . If the parent's voltage drops below the commanded output voltage, the UCD9112 will follow the parent's voltage down to at least 300mV.

If the device is requested to shut down through any legal combination of the OPERATION command and/or the CONTROL line, then it performs soft-stop according to PMBus configuration (by following TOFF\_DELAY and TOFF\_FALL timings).

If any fault condition causes the output to shutdown, then the converter turns the output off according to the fault configuration.

## OTHER FUNCTIONS (continued)

If the parent supply is turned on before the tracking device is commanded to start tracking, then the tracking device will either reach its VOUT\_COMMAND voltage or the parent's output voltage; whichever is lower.

If voltage tracking feature is disabled, the device follows the standard soft-start/soft-stop configuration and TRACK pin voltage is ignored.

Like other analog inputs on the UCD9112, the voltage on the TRACK pin may have to be scaled to fit within the range of the ADC, and there are PMBus commands that allow the gain and offset of the tracking voltage to be configured. For more details, refer to the "PMBus Support for the UCD911X" application note.

### Fault Handling

The UCD9112 provides the capability to monitor input voltage, output voltage, output current, temperature, and fan speed. These thresholds and responses to these faults are programmable through PMBus, as well as the status of these parameters during converter operation.

Refer to the PMBus Command Protocol Specification (version 1.1) and "PMBus Support for the UCD911X" application note for more information on fault handling.

### Fault Logging

The UCD9112 has the capability to provide fault logging to non-volatile memory when faults occur during operation. This can be useful for diagnosing failures of the power converter. The UCD9112 will record the maximum lifetime temperature that the remote sensor observed during operation, once it crosses the over-temperature warning limit. The UCD9112 will also record the reason for any operating fault as well (voltage, temperature, current, start-up or fan). Both of these sets of faults are stored in non-volatile memory in the device and can be cleared by a user command.

For more details on logged faults and how to retrieve them from the UCD9112, see "PMBus Support for the UCD911X" application note.

### Over-current Protection

The UCD9112 works with the UCD7230 gate driver to measure output current and provide output current protection. The UCD9112 and UCD7230 system provides three levels of over-current protection.

First, cycle-by-cycle current is monitored in the UCD7230 by sensing the current of top MOSFET. A current limit threshold can be configured through external resistors on the CS+ and CSBIAS inputs to the UCD7230 (See the UCD7230 data sheet for more information). The MOSFET current is compared to the current threshold and if it is higher than the threshold, the duty-cycle is terminated for the remaining period. The current limit flag output (CLF) of the UCD7230 is become a logic high. The CLF is kept high for the next switching cycle. The CLF will be reset at the rising edge of the second switching cycle if over current is not detected during the next period. If the over current remains, the CLF remains high. The UCD9112 counts the number of switching cycles when the CLF is high. If the count is higher than a configurable limit in the UCD9112, the device can be configured to shut off the DPWM outputs. The converter would then enter hiccup mode or latched-off mode per the configured fault response. When CLF is low, the count is reset.

The second level of current protection is configurable (both the current limit and what to do when that limit is exceeded). The output current is obtained by using the DCR current method described in the Output Current Calibration section. The UCD9112 provides a current limit ( $I_{LIM}$ ) threshold for the UCD7230 through a filtered PWM output. The  $I_{sense}$  voltage is compared to  $V_{LIM}/10$  (the voltage on ILIM pin of UCD7230) by a high speed comparator inside the UCD7230. If  $I_{sense} > V_{LIM}/10$ , the CLF is set and the duty-cycle is terminated. The current limit threshold and the number of switching pulses are configurable through the PMBus on the UCD9112 controller.

To program the UCD7230 ILIM, the filter (R1 and C1) shown in the [Figure 9](#) is required.

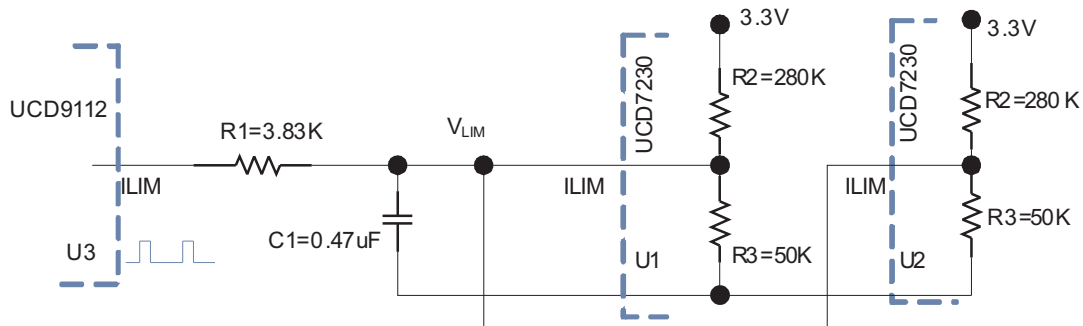
**OTHER FUNCTIONS (continued)****Figure 9. RC filter used for  $I_{LIM}$** 

The resistor R1 has two functions, one is to form a low pass filter, and the other is to form a voltage divider along with R2 and R3. To configure the current limit threshold, the user simply needs to instruct the UCD9112 controller via PMBus what the desired current limit is in amperes. The controller will generate the proper  $V_{LIM}$  to the UCD7230 gate driver for the desired current limit.

The last level of over-current protection is provided by the UCD9112 and uses average current for protection. This protection responds slower but can be more accurate. The UCD9112 monitors each phase current from an input from the UCD7230 gate driver. This is an average current measurement, and it is compared with a threshold to determine if there is over current fault or not. The UCD9112 will then act on this fault according to the configured response, which can be ignore, retry, delay or shutdown.

See “PMBus Support for the UCD911X” application note for more details on configuring over-current thresholds and responses.

**Power Good (PGOOD)**

The UCD9112 supports a power good signal (PGOOD). PGOOD can notify other devices or the host about the operating condition of power supply at a fast speed in order that necessary actions should be taken to avoid any data losses. It is implemented by PGOOD pin of the UCD9112.

The UCD9112 monitors the output voltage, and then either asserts or de-asserts the power good signal based on the voltage. The polarity of PGOOD can be configured to be active high or active low and the threshold can be programmed using the PMBus.

**Fan Speed Adjustment and Monitor**

The UCD9112 is capable of generating PWM pulses to drive a single fan installed in the system. The fan PWM (FFAN) frequency generated by the UCD9112 is fixed at about 700Hz. The fan speed can be varied by adjusting the average supplied voltage to the fan which in turn can be adjusted by changing the duty cycle. Thus, the PMBus master can control the fan speed by issuing the relevant PMBus command. The fan's TACH output needs to be connected to FAN\_TACH input pin of UCD9112 for fan speed monitoring. The PMBus master can query the fan speed (in RPM) by issuing the relevant PMBus command. The number of pulses per revolution is configurable. The UCD9112 supports 8 different fan speeds as listed in the [Table 4](#).



**Table 4. FAN duty cycle commands**

COMMANDED FAN DUTY CYCLE	ACTUAL FAN DUTY CYCLE
0% to 7%	0%
8% to 21%	14.3%
22% to 35%	28.6%
36% to 50%	43%
51% to 64%	57%
65% to 78%	71.4%
79% to 92%	85.7%
93% to 100%	100%

If the fan's actual speed falls below the configured FAN\_SPEED\_FAULT\_LIMIT, the fan fault is generated and the relevant status registers get updated accordingly.

For more details, refer to the "PMBus Support for the UCD911X" application note.

### Light Load Efficiency Optimization

A dual phase power supply has several advantages over a single phase supply. The two major advantages are improved efficiency and lower output ripple.

Though a dual phase power supply has better efficiency for a typical or heavy load, it actually offers lower efficiency for lighter loads. The UCD9112 allows phase shedding in order to boost back the efficiency at lighter loads. The PMBus master can set the UCD9112 into light load mode by a PMBus command. In light load mode, only one phase is operational. Due to this, switching losses are cut into half and efficiency improves.

By default, the light load mode is disabled. For more details, refer to the "PMBus Support for the UCD911X" application note

### Remote Temperature Sensing

The UCD9112 has support for internal and remote temperature sensing. The internal temperature sensor requires no calibration and can report the device temperature via the PMBus interface. See "PMBus Support for the UCD911X" application note on the PMBus command to access the internal temperature sensor.

The remote temperature sensor can report the remote temperature by using a configurable gain and offset for the type of sensor that is used in the application (P-N junction or a linear temperature sensor (LTS)). The UCD9112 allows warning and fault thresholds to be configured for under and over-temperature based on the remote temperature (and not the internal sensor). Both the configurable thresholds as well as the reported temperature are available via the PMBus interface on the device. See "PMBus Support for the UCD911X" application note for more details.

The remote temperature is sensed through the TEMP pin of the device. A LTS or a P-N junction can be used for the temperature sensor. A thermistor can be configured to provide a somewhat linear response over a narrow range of temperatures. It may be acceptable in some applications to use a thermistor where the response has been linearized near the warning and fault thresholds. A P-N junction has an advantage of lower cost and a linear response to temperature changes. The UCD9112 uses a P-N junction on its evaluation module (EVM) to sense the temperature. It is located close to the inductor so that the inductor's temperature can be sensed. It is used for temperature protection as well as DCR compensation. The gain and offset of P-N junction can be configured through the PMBus to calibrate the sensor. Since the gain and offset are the only variables that are configurable to report the temperature, it is advised to use a sensor that is relatively linear over the range of interest.

### Configuration Security

The UCD9112 provides a configuration security mechanism to allow the user to protect the configuration from unwanted changes. The device can be configured so that only an administrator will be permitted to make the changes by entering a password and specifying which parameters users should be allowed to change via PMBus.

For complete details on the capabilities and usage of Configuration Security, refer to the PMBus Security Application Note.

## GRAPHICAL USER INTERFACE

All TI digital controllers come with a Graphical User Interface (GUI) that supports configuration, monitoring and design of any power converter built with the UCD9K family of digital controllers.

The key functions of the GUI for the UCD9112 are listed below:

- PID coefficients programming
- POL ON/OFF
- Voltage and current calibration
- POL parameter configuration
- Read output voltage, output current, temperature
- Fault threshold configuration
- Manufacturing information storage

In addition to the above, the GUI assists users with the design of their power converters using the UCD9112 and UCD7230 gate driver. The design portion of the GUI allows users to simulate and model the plant, digital compensator and loop response in both the Continuous and Discrete domains. The GUI can also help generate the digital compensator loop coefficients and save them as a project file in your PC, and send them to the device via the PMBus for evaluation and testing.

For more information on the capabilities of the GUI, please see the Fusion Digital Power Designer User Manual.

**APPENDIX A**
**Table 5. List of Acronyms in the Datasheet**

ACRONYM	DESCRIPTION
POL	Point of load
AG	Analog ground
DG	Digital ground
POR	Power on reset
$T_j$	Junction temperature
$T_{sj}$	Storage temperature
$t_r$	Rise time
$t_f$	Fall time
$F_{sw}$	PWM switching frequency
$F_{FAN}$	Fan drive PWM frequency
$V_{OL}$	Low level output voltage
$V_{OH}$	High level output voltage
$V_{IL}$	Low level input voltage
$V_{IH}$	High level input voltage
$V_{out}$	Output voltage
$V_{in}$	Input voltage
$I_{out}$	Output current
CLF	Current limit flag
$I_{sense}$	Current sensing voltage
$V_{LIM}$	Voltage on the ILIM pin of UCD7230
A	Analog
D	Digital
P	Power
VD33	3.3V supply for the device
ICC	Bias current for the device
$V_{ILMAX}$	Maximum input low level voltage
$V_{IHMIN}$	Minimum input high level voltage
$R_{in}$	ADC input impedance
$C_{in}$	External input capacitor
$S_{S/H}$	ADC sampling and hold switch
$C_{S/H}$	ADC sampling and hold capacitor
PID	Proportional-integral-derivative
GUI	Graphic user interface
EADC	Error ADC
Vaddr	Voltage on ADDR0 or ADDR1 pin
T_Rise	Output rise time
T_Fall	Output fall time
SRE	Synchronous rectifier enable
$F_{ILIM}$	PWM frequency for $I_{LIM}$

**REFERENCES**

- PMBus Support in UCD911x Family of Digital Power Controllers - SLUA427
- Configuration Security for UCD91xx Digital Controllers - SLUA428

**PACKAGING INFORMATION**

Orderable Device	Status <sup>(1)</sup>	Package Type	Package Drawing	Pins	Package Qty	Eco Plan <sup>(2)</sup>	Lead/Ball Finish	MSL Peak Temp <sup>(3)</sup>
UCD9112RHBR	ACTIVE	QFN	RHB	32	3000	Green (RoHS & no Sb/Br)	CU NIPDAU	Level-2-260C-1 YEAR
UCD9112RHBRG4	ACTIVE	QFN	RHB	32	3000	Green (RoHS & no Sb/Br)	CU NIPDAU	Level-2-260C-1 YEAR
UCD9112RHBT	ACTIVE	QFN	RHB	32	250	Green (RoHS & no Sb/Br)	CU NIPDAU	Level-2-260C-1 YEAR
UCD9112RHBTG4	ACTIVE	QFN	RHB	32	250	Green (RoHS & no Sb/Br)	CU NIPDAU	Level-2-260C-1 YEAR

<sup>(1)</sup> The marketing status values are defined as follows:

**ACTIVE:** Product device recommended for new designs.

**LIFEBUY:** TI has announced that the device will be discontinued, and a lifetime-buy period is in effect.

**NRND:** Not recommended for new designs. Device is in production to support existing customers, but TI does not recommend using this part in a new design.

**PREVIEW:** Device has been announced but is not in production. Samples may or may not be available.

**OBSOLETE:** TI has discontinued the production of the device.

<sup>(2)</sup> Eco Plan - The planned eco-friendly classification: Pb-Free (RoHS), Pb-Free (RoHS Exempt), or Green (RoHS & no Sb/Br) - please check <http://www.ti.com/productcontent> for the latest availability information and additional product content details.

**TBD:** The Pb-Free/Green conversion plan has not been defined.

**Pb-Free (RoHS):** TI's terms "Lead-Free" or "Pb-Free" mean semiconductor products that are compatible with the current RoHS requirements for all 6 substances, including the requirement that lead not exceed 0.1% by weight in homogeneous materials. Where designed to be soldered at high temperatures, TI Pb-Free products are suitable for use in specified lead-free processes.

**Pb-Free (RoHS Exempt):** This component has a RoHS exemption for either 1) lead-based flip-chip solder bumps used between the die and package, or 2) lead-based die adhesive used between the die and leadframe. The component is otherwise considered Pb-Free (RoHS compatible) as defined above.

**Green (RoHS & no Sb/Br):** TI defines "Green" to mean Pb-Free (RoHS compatible), and free of Bromine (Br) and Antimony (Sb) based flame retardants (Br or Sb do not exceed 0.1% by weight in homogeneous material)

<sup>(3)</sup> MSL, Peak Temp. -- The Moisture Sensitivity Level rating according to the JEDEC industry standard classifications, and peak solder temperature.

**Important Information and Disclaimer:**The information provided on this page represents TI's knowledge and belief as of the date that it is provided. TI bases its knowledge and belief on information provided by third parties, and makes no representation or warranty as to the accuracy of such information. Efforts are underway to better integrate information from third parties. TI has taken and continues to take reasonable steps to provide representative and accurate information but may not have conducted destructive testing or chemical analysis on incoming materials and chemicals. TI and TI suppliers consider certain information to be proprietary, and thus CAS numbers and other limited information may not be available for release.

In no event shall TI's liability arising out of such information exceed the total purchase price of the TI part(s) at issue in this document sold by TI to Customer on an annual basis.

RHB (S-PQFP-N32)

PLASTIC QUAD FLATPACK

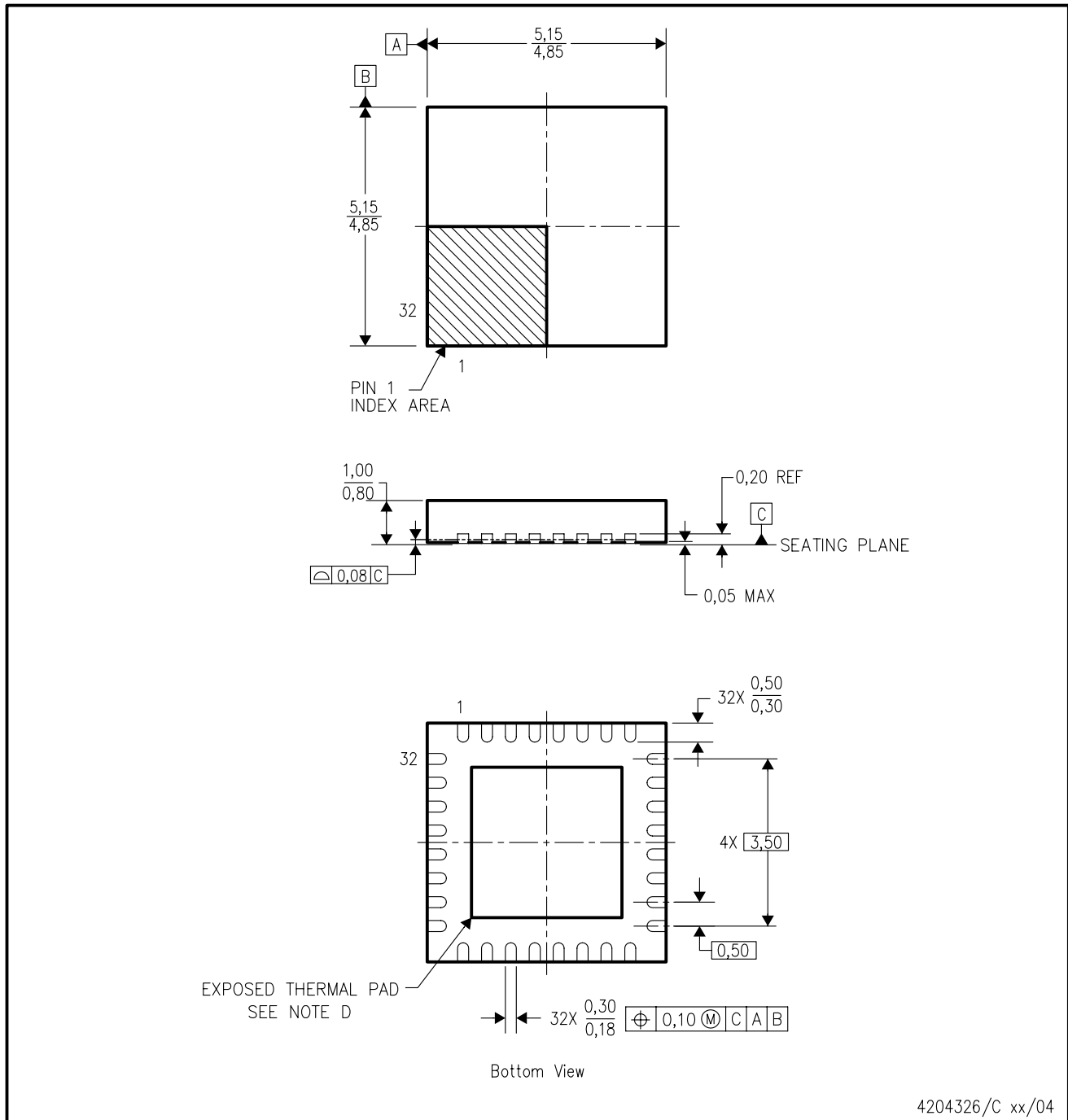

- NOTES:
- All linear dimensions are in millimeters.
  - This drawing is subject to change without notice.
  - QFN (Quad Flatpack No-Lead) Package configuration.
  - The Package thermal pad must be soldered to the board for thermal and mechanical performance. See product data sheet for details regarding the exposed thermal pad dimensions.
  - Falls within JEDEC MO-220.

## IMPORTANT NOTICE

Texas Instruments Incorporated and its subsidiaries (TI) reserve the right to make corrections, modifications, enhancements, improvements, and other changes to its products and services at any time and to discontinue any product or service without notice. Customers should obtain the latest relevant information before placing orders and should verify that such information is current and complete. All products are sold subject to TI's terms and conditions of sale supplied at the time of order acknowledgment.

TI warrants performance of its hardware products to the specifications applicable at the time of sale in accordance with TI's standard warranty. Testing and other quality control techniques are used to the extent TI deems necessary to support this warranty. Except where mandated by government requirements, testing of all parameters of each product is not necessarily performed.

TI assumes no liability for applications assistance or customer product design. Customers are responsible for their products and applications using TI components. To minimize the risks associated with customer products and applications, customers should provide adequate design and operating safeguards.

TI does not warrant or represent that any license, either express or implied, is granted under any TI patent right, copyright, mask work right, or other TI intellectual property right relating to any combination, machine, or process in which TI products or services are used. Information published by TI regarding third-party products or services does not constitute a license from TI to use such products or services or a warranty or endorsement thereof. Use of such information may require a license from a third party under the patents or other intellectual property of the third party, or a license from TI under the patents or other intellectual property of TI.

Reproduction of TI information in TI data books or data sheets is permissible only if reproduction is without alteration and is accompanied by all associated warranties, conditions, limitations, and notices. Reproduction of this information with alteration is an unfair and deceptive business practice. TI is not responsible or liable for such altered documentation. Information of third parties may be subject to additional restrictions.

Resale of TI products or services with statements different from or beyond the parameters stated by TI for that product or service voids all express and any implied warranties for the associated TI product or service and is an unfair and deceptive business practice. TI is not responsible or liable for any such statements.

TI products are not authorized for use in safety-critical applications (such as life support) where a failure of the TI product would reasonably be expected to cause severe personal injury or death, unless officers of the parties have executed an agreement specifically governing such use. Buyers represent that they have all necessary expertise in the safety and regulatory ramifications of their applications, and acknowledge and agree that they are solely responsible for all legal, regulatory and safety-related requirements concerning their products and any use of TI products in such safety-critical applications, notwithstanding any applications-related information or support that may be provided by TI. Further, Buyers must fully indemnify TI and its representatives against any damages arising out of the use of TI products in such safety-critical applications.

TI products are neither designed nor intended for use in military/aerospace applications or environments unless the TI products are specifically designated by TI as military-grade or "enhanced plastic." Only products designated by TI as military-grade meet military specifications. Buyers acknowledge and agree that any such use of TI products which TI has not designated as military-grade is solely at the Buyer's risk, and that they are solely responsible for compliance with all legal and regulatory requirements in connection with such use.

TI products are neither designed nor intended for use in automotive applications or environments unless the specific TI products are designated by TI as compliant with ISO/TS 16949 requirements. Buyers acknowledge and agree that, if they use any non-designated products in automotive applications, TI will not be responsible for any failure to meet such requirements.

Following are URLs where you can obtain information on other Texas Instruments products and application solutions:

### Products

Amplifiers	<a href="http://amplifier.ti.com">amplifier.ti.com</a>
Data Converters	<a href="http://dataconverter.ti.com">dataconverter.ti.com</a>
DSP	<a href="http://dsp.ti.com">dsp.ti.com</a>
Clocks and Timers	<a href="http://www.ti.com/clocks">www.ti.com/clocks</a>
Interface	<a href="http://interface.ti.com">interface.ti.com</a>
Logic	<a href="http://logic.ti.com">logic.ti.com</a>
Power Mgmt	<a href="http://power.ti.com">power.ti.com</a>
Microcontrollers	<a href="http://microcontroller.ti.com">microcontroller.ti.com</a>
RFID	<a href="http://www.ti-rfid.com">www.ti-rfid.com</a>
RF/IF and ZigBee® Solutions	<a href="http://www.ti.com/lprf">www.ti.com/lprf</a>

### Applications

Audio	<a href="http://www.ti.com/audio">www.ti.com/audio</a>
Automotive	<a href="http://www.ti.com/automotive">www.ti.com/automotive</a>
Broadband	<a href="http://www.ti.com/broadband">www.ti.com/broadband</a>
Digital Control	<a href="http://www.ti.com/digitalcontrol">www.ti.com/digitalcontrol</a>
Medical	<a href="http://www.ti.com/medical">www.ti.com/medical</a>
Military	<a href="http://www.ti.com/military">www.ti.com/military</a>
Optical Networking	<a href="http://www.ti.com/opticalnetwork">www.ti.com/opticalnetwork</a>
Security	<a href="http://www.ti.com/security">www.ti.com/security</a>
Telephony	<a href="http://www.ti.com/telephony">www.ti.com/telephony</a>
Video & Imaging	<a href="http://www.ti.com/video">www.ti.com/video</a>
Wireless	<a href="http://www.ti.com/wireless">www.ti.com/wireless</a>

Mailing Address: Texas Instruments, Post Office Box 655303, Dallas, Texas 75265  
Copyright © 2008, Texas Instruments Incorporated